

CONTENTS

CHAPTER I engine introduction

- 1.1 Main specifications
- 1.2 Main accessories specifications
- 1.3 Fitting clearance and wearing limits of the main moving parts
- 1.4 Main limits of working torque

PREFACE

Please read the manual of operation carefully before operate the engine ,and the operator should maintain it strictly as required.

The engine is improved from time to time ,so the manual of operation may be different from the engine ,please draw attentions to it .The engine NO.is engraved in the central position of cylinder-block upper end by the side of the fly wheel.

CHAPTER III engine maintenance

- 3.1 Daily maintenance
- 3.2 Maintenance after 100 hours
- 3.3 Maintenance after 500 hours
- 3.4 Engine preservation storage

CHAPTER IV the structure of engine

- 4.1 Crankshaft and flywheel assembly
- 4.2 Cylinder head assembly
- 4.3 Crankshaft and flywheel
- 4.4 Piston-connecting rod assembly
- 4.5 Drive mechanism

PRECAUTIONS

To ensure the availability and a long service-life, the engine should be operated and maintained strictly as required .

Never let the engine run in overload ,or the engine will be damaged .To avoid premature wearing of the engine parts ,do not allow to run the engine with high speed in the period of commissioning.

If not necessary ,don't run the engine with high speed . While running with low ger ,the engine should keep running in low speed .Cooling water should be soft-water.

Do not allow to frequently work in the condition of boiling or in high temperature water (over 95℃).

Please choose the real parts supplied by our works or appointed one by our works.

Willkeep the manual of operation and transfer it with the engine.

CONTENTS

CHAPTER I engine introduction.....	1
1. Main specifications	
2. Main accessories specifications:	
3. Fitting clearances and wearing limits of the main moving parts	
4. Main bolts tightening torque	
CHAPTER II engine operation and precautions.....	5
1. Engine operation	
2. Precautions when operating	
3. Assembling air filter	
CHAPTER III engine maintenance.....	7
1. Daily maintenance	
2. Maintenance after 100 hours	
3. Maintenance after 500 hours	
4. Engine preservation storage	
CHAPTER IV the structure of engine.....	10
1. Cylinder block assembly	
2. Cylinder head assembly	
3. Crankshaft and flywheel assembly	
4. Piston-connecting rod assembly	
5. Driving mechanism	
6. valae system	
7. Fuel supply system	
8. Lubrication system	
9. Cooling system	
10. Electric systsem	
CHAPTER V engine trouble and remedy.....	17
A. Engine can not be started	
B. Engine power declines	
C. Engine stops suddenly	
D. Engine running with knocking sound	
E. Oil pressure too low	
F. Engine over heat	
G. Encine exhausts abnormal smoke	
H. Troubles and remedies of the fuel injection pump	
I. Starter is out of order	
J. Alternator is out of order	

CHAPTER I ENGINE INTRODUCTION

1. MAIN SPECIFICATIONS

Dynamic Norm of the Engine(the power of each type is show on the nameplate)

3T30 Diesel Engine		
order	Rated Power/Speed(KW/rpm)	Max Torque/Speed(N • m/rpm)
1	23.5/2350	110/1650
2	22.1/2350	103/1650
3	20.6/2350	96/1650
4		
5		

Main Paraments of the Diesel Engine

	MODEL	3T30
SPECIFICATION	MODEL	3T30
Type	In---Line, water---cooling, direct injector	
No. of Cylinder	3	
Cylinder bore(mm)	85	
Piston stroke(mm)	95	
Compression ratio	18	
Displacement(L)	1.617	
Cylinder working sequence	1—3—2	
Lowest steady speed without load(rpm)	≤850	
Lowest fuel consumption at full load(g/KW.h)	≤238	
Oil consumption at full load(g/kw.h)	≤0.5%	
Oil pressure	At idle speed(kpa)	≥50
	At rated speed(kpa)	300~450
Crankshaft rotating direction	counterclockwise	
Injection advance angle(T.D.C)	14±1	
Fuel injection pressure(kpa)	19000~20000	
Valve timing phase	Intake valve open	14.5° before T.D.C
	Intake valve close	37.5° after B.D.C
	Exhaust valve open	56° before B.D.C
	Exhaust valve close	12° after T.D.C
Valve clearance	Intake valve(mm)	0.20~0.30
	Exhaust valve(mm)	0.25~0.35
Valve sinkage	Intake valve(mm)	0.7~0.9
	Exhaust valve(mm)	0.7~0.9
Steady speed adjusting ratio at rated conditon	≤10%	
Oil sump capacity(L)	6	

CHAPTER I ENGINE INTRODUCTION

1. MAIN SPECIFICATIONS

Temperature(°C)	Water outlet	75~85
	Oil	85~95
	Exhaust pipe	≤650
Starting method		Electric starting
Lubricating method		Pressure & splash
Cooling method		Water cooling
Overall dimension (L×W×H) (mm)		567×584×625
Net weight (kg)		200
Applications		Tractor, engineering machine
Characteristics		Assembling two hydraulic pumps and one air pump at one time

2. MAIN ACCESSORIES SPECIFICATIONS

Model		3T30
Injection pump	Model	IW or BQ
	Type	Plunger
	Plunger diameter (mm)	Φ9
Nozzle tip model		LT-Z2066
Starter		QD1315A (12V, 2.5Kw)
Alternator		JF11 (14V, 350W) or JFWB13A1 (14V, 350W)
Water pump		Centrifugal, ≥112L/min
Oil pump		Rotary, ≥38L/min
Fuel filter	Model	CX0706
	Type	—
Oil filter	Model	WB447
	Type	Rotary

3. FITTING

No.	
1	Main main
2	Axial cranks
3	Crank and bearing
4	Connect end clear
5	Piston connect small hole
6	Piston pin seal
7	Piston cylinder
8	Piston opening
9	First slot
10	Second ring and
11	Oil seal and its

3. FITTING CLEARANCES AND WEAR LIMITS OF THE MAIN MOVING PARTS

单位: mm

No.	NAME	STANDARD SIZE	FITTING	NEW ENGINE FITTING CLEARANCE	LIMIT ALLOWANCE
1	Main journal and main bearing hole	Shaft $\phi 65 \begin{smallmatrix} 0 \\ -0.019 \end{smallmatrix}$	Clearance fit	0.064~0.128	0.25
		Hole $\phi 65 \begin{smallmatrix} +0.109 \\ +0.064 \end{smallmatrix}$			
2	Axial clearance of crankshaft	$28 \begin{smallmatrix} -0.075 \\ -0.165 \end{smallmatrix}$	Clearance fit	0.075~0.215	0.50
		$28_0 \begin{smallmatrix} +0.05 \\ 0 \end{smallmatrix}$			
3	Crankshaft journal and connecting rod bearing hole	shaft $\phi 53 \begin{smallmatrix} 0 \\ -0.019 \end{smallmatrix}$	Clearance fit	0.04~0.094	0.20
		hole $\phi 53 \begin{smallmatrix} +0.075 \\ +0.04 \end{smallmatrix}$			
4	Connecting rod big end facing clearance	$30 \begin{smallmatrix} -0.14 \\ -0.22 \end{smallmatrix}$	Clearance fit	0.14~0.32	
		$30_0 \begin{smallmatrix} +0.10 \\ 0 \end{smallmatrix}$			
5	Piston pin & connecting rod small end bushing hole	Shaft $\phi 29 \begin{smallmatrix} 0 \\ -0.006 \end{smallmatrix}$	Clearance fit	0.025~0.044	0.10
		Hole $\phi 29 \begin{smallmatrix} +0.038 \\ +0.025 \end{smallmatrix}$			
6	Piston pin & piston pin seat hole	Shaft $\phi 29 \begin{smallmatrix} 0 \\ -0.004 \end{smallmatrix}$	Interim fit	-0.0045~+0.0105	
		Hole $\phi 29 \pm 0.0045$			
7	Piston skirt & cylinder liner	Skirt $85 \begin{smallmatrix} -0.105 \\ -0.12 \end{smallmatrix}$	Clearance fit	0.105~0.135	
		$\phi 85 \begin{smallmatrix} +0.015 \\ 0 \end{smallmatrix}$			
8	Piston ring opening clearance	First ring		0.30~0.50	2.2
		Third ring & oil ring		0.25~0.45	
9	First ring and its slot		Clearance fit	0.095~0.145	0.20
10	Second & third ring and its slot		Clearance fit	0.04~0.072	0.18
11	Oil scraper ring and its slot		Clearance fits	0.03~0.062	0.18

No	NAME	STANDARD SIZE	FITTING	NEW ENGINE FITTING CLEARANCE	LIMIT ALLOWANCE
12	Camshaft journal and its bushing	Shaft $\phi 44c7$ ($\begin{smallmatrix} -0.050 \\ -0.075 \end{smallmatrix}$)	Clearance	0.05~0.1	0.20
		Hole $\phi 44_0$ $\begin{smallmatrix} +0.025 \\ 0 \end{smallmatrix}$	fit		
13	Camshaft axial clearance	S $\begin{smallmatrix} -0.09 \\ -0.145 \end{smallmatrix}$	Clearance	0.09~0.245	0.60
		S_0 $\begin{smallmatrix} +0.10 \\ 0 \end{smallmatrix}$	fit		
14	Valve tappet and its hole	Shaft $\phi 13f6$ ($\begin{smallmatrix} -0.016 \\ -0.027 \end{smallmatrix}$)	Clearance	0.016~0.045	0.25
		Hole $\phi 13H7_0$ $\begin{smallmatrix} +0.018 \\ 0 \end{smallmatrix}$	fit		
15	Rocker arm shaft and shaft hole	Shaft $\phi 16f6$ ($\begin{smallmatrix} -0.016 \\ -0.027 \end{smallmatrix}$)	Clearance	0.016~0.045	0.20
		Hole $\phi 16H7_0$ $\begin{smallmatrix} +0.018 \\ 0 \end{smallmatrix}$	fit		
16	Intake valve and valve guide hole	Shaft $\phi 8c8$ ($\begin{smallmatrix} -0.025 \\ -0.047 \end{smallmatrix}$)	Clearance	0.025~0.069	0.15
		Hole $\phi 8H8_0$ $\begin{smallmatrix} +0.022 \\ 0 \end{smallmatrix}$	fit		
17	Exhaust valve and valve guide hole	Shaft $\phi 8d7$ ($\begin{smallmatrix} -0.040 \\ -0.055 \end{smallmatrix}$)	Clearance	0.040~0.077	0.15
		Hole $\phi 8H8_0$ $\begin{smallmatrix} +0.022 \\ 0 \end{smallmatrix}$	fit		
18	Idle gear shaft journal and bushing hole	Shaft $\phi 44f7$ ($\begin{smallmatrix} -0.025 \\ -0.050 \end{smallmatrix}$)	Clearance	0.025~0.089	0.20
		Hole $\phi 44H7_0$ $\begin{smallmatrix} +0.039 \\ 0 \end{smallmatrix}$	fit		
19	Idle gear end facing clearance		Clearance	0.15~0.32	
			fit		
20	Gears engaging side clearance		Clearance fit	0.11~0.18	0.30

4. MAIN BOLT TIGHTENING TORQUE

Cylinder head bolt	135~150 N.m
Main bearing cover bolt	115-130 N.m
Connecting rod bolt	80~90 N.m
Fly wheel bolt	50~60 N.m
Idle gear shaft bolt (for 4L22T, 4L22BT)	50~60 N.m

1. ENGI

Fuel, oi

1) Fuel

Fue

2) Coolin

Wa

always :

cooling

when th

Inspecti

1) Chec

stop lev

2) Runn

3) Chec

side of

4) Chec

connect

5) Chec

6) Cher

water p

7) Chec

Chec

Chec

bondin

Engine

1) Set s

2) Loo

delivery

stocked

3) To s

seconds

LIMIT ALLOWANCE
0.20
0.60
0.25
0.20
0.15
0.15
0.20
0.30

CHAPTER II

ENGINE OPERATION AND PRECAUTIONS

1. ENGINE OPERATION

Fuel, oil and cooling water

1) Fuel and oil:

Fuel and oil selected subject to local ambient temperature.

2) Cooling water:

Water of rain or clear river water is always preferably selected as cooling water. You are always suggested to fill some anti-frozen liquid in cooling system in cold winter. Heat the cooling water up to 80°C before filling it into the water tank, if the engine is hard to start, when the ambient temperature is below 0°C.

Inspection and preparation before starting:

1) Check each connection for tightness, check operation levers such as fuel supply lever, engine stop lever whether they are running freely.

2) Running the crankshaft several turns, check each part for running smoothly.

3) Check the oil level in oil sump and injection pump to ensure that the oil level is at the upper side of the oil dipstick mark.

4) Check water tank for full of cooling water and whether there is any leakage on water pipe connections.

5) Check fuel tank for full of fuel and fuel pipes for smooth flowing and its leakage.

6) Check each attached parts for correct connection as injection pump, fuel filter, oil filter, water pump, fan, generator and its bracket, fan belt, starter and water tank etc.

7) Check each connector of electrical system for correctness, tightness.

Check alternator for sufficient voltage.

Check alternator for negative electrode bonding and the accumulator for negative electrode bonding.

Engine starting

1) Set speed adjusting level at middle position.

2) Loosen the air exhaust screw on fuel filter, continuously press the hand - operated fuel delivery pump to discharge the air inside fuel system, especially for new engine or engines stocked for long time.

3) To start the engine first turn the switch to "pre-heat" position to heat the engine for 25-30 seconds.. Then turn to "pre-heat" position to start the engine. Repeat as above procedures in

2 minutes, if you failed to start the engine.

4) After starting, immediately adjust fuel supply to make the engine running at idle speed. Care should be taken to ensure that the oil pressure is up to 50kPa, then gradually increase speed to warm up the engine without load.

Engine running

- 1) Engine is only allowed working with load when the cooling water temperature is up to 50°C. Running at rated power when the cooling water temperature is about 80°C.
- 2) Increasing or decreasing the load and speed should be smoothly and gradually carried out. Normally is not allowed to increase or decrease the load suddenly.
- 3) During engine operation, care must be taken to see whether the meter is normal, the colour of exhaust air and the sound of running. Should any abnormal appears, stop the engine and check.

Engine stopping

- 1) Before stopping the engine, lower the speed to the idle condition and gradually discharge the load until the water temperature comes down below 70°C, then the engine can be stopped by stop—lever.
- 2) After the engine stopped, turn the switch to middle position.
- 3) After the engine stopped, draining the cooling water by opening the water cock on both cylinder block and water tank while the cooling water temperature comes down below 60°C. When ambient temperature below 5°C. Draining is not necessary when anti-frozen liquid is filled.

2. PRECAUTIONS WHEN OPERATION

Engine should be maintained and adjusted according to the stipulation in the operation manual.

Full speed and full load operation is not allowed for the new or repaired engine. First wearing-in should be carried out for 45 hours in low speed and load. Then the engine could be put in normal load operation.

Engine fuel should be precipitated and filtered clean.

Keep normal water temperature at 75°C - 85°C, normal oil Pressure at 300-450kPa.

3. ASSEMBLING AIR FILTER.

Air filter should be correctly, reasonably and tightly assembled at a suitable place on back or front of the chassis of cabin, and connected to intake pipe by rubber wave pipe which both ends should be tightened with clips. The dirt discharge port should be downwards.

To
following p

1. DAILY

Check
oil dipstick
Check
Check
when insuf
Check
Check
Check
Keep
the electric
load, oil sh
Remov

2. MAINT

Replac
Clean o
Clean o
Check t
Check v
Check f
Remove
Check
necessary.
Check t
29, when air
Check v
fill in vapor
Replace
Take out
speed alterna
stop the eng
water.

CHAPTER III ENGINE MAINTENANCE

To ensure a longer service life, the engine should be maintained according to the following procedure.

1. DAILY MAINTENANCE

Check the oil level in oil sump, to ensure the oil level be between the two marks on the oil dipstick.

Check water quantity in water tank.

Check the oil level in injection pump and speed adjustor, refill to specified position when insufficient.

Check and remove any oil, fuel, water and gas leakage.

Check for the tightness of each attached parts.

Check for the tightness of engine bracket.

Keep the engine clean, and remove dirt and mud. Special care must be taken to ensure the electrical equipments dry and clean. After 45 hours wearing - in of new engine with light load, oil should be replaced and the oil filter cartridge should be cleaned in time.

Remove other troubles and abnormals.

2. MAINTENANCE AFTER 100 HOURS

Replace oil in oil sump

Clean or replace oil filter cartridge.

Clean or replace fuel filter cartridge (or after 200 hours)

Check for tightness of cylinder head bolts.

Check valve clearance and adjust when necessary.

Check fan belt tightness and adjust when necessary.

Remove dirt in intake pipe and air filter.

Check injection and injection pressure after 200 hours. Clean and adjust when necessary.

Check tile accumulator voltage. The specific gravity of electrolyte should be 1.28 - 1.29, when air temperature at 15°C. It is normally not lower than 1.27.

Check whether the electrolyte level is 10 to 15mm higher than polar plates. Otherwise fill in vaporized water.

Replace cooling water when not clean.

Take out thermostat, assemble water outlet pipe, start the engine and change the engine speed alternatively so as to change the cooling water flow speed to wash out sediment. Then stop the engine and open the water cock both on cylinder block and water tank to drain water.

While fill clean water into the water tank, restart the engine and run in idle to make water flow. Close the water cocks as soon as the drained water is clean. Stop the engine and reassemble the thermostat.

To ensure the parts disassembled for maintenance are reassembled correctly.

3. MAINTENANCE AFTER 500 HOURS

Carry out the follow procedure besides item 2.

Check full injection pressure and atomization quality. Clean and adjust when necessary.

Check injection advance angle and adjust when necessary.

Dismount cylinder head; Remove carbon deposit; Check valve sealing and lap when necessary.

Check connecting rod bolts, main bearing bolts and flywheel bolts for tightness.

Re-tighten the cylinder head bolts according to the sequence shown in Fig. 1, and adjust the valve clearance.

Clean or replace air filter cartridge (may proceed earlier according to working condition)

Replace oil in injection pump and speed adjustor.

Clean cooling system. Cleaning fluid is mixture of 150g NaOH and 1 liter water completely. Drain out the cooling water before cleaning, then fill in cleaning fluid and run the engine after 8-12 hours. Stop the engine when working water temperature is achieved, drain out cooling fluid immediately to prevent the inflow scale depositing, finally clean the cooling system with clean water.

Check thermostat working.

Check each electrical starting equipment to ensure all tightness and wiring connections are tighten. Replace those burned out.

Check all engine parts, repair or adjust when necessary.

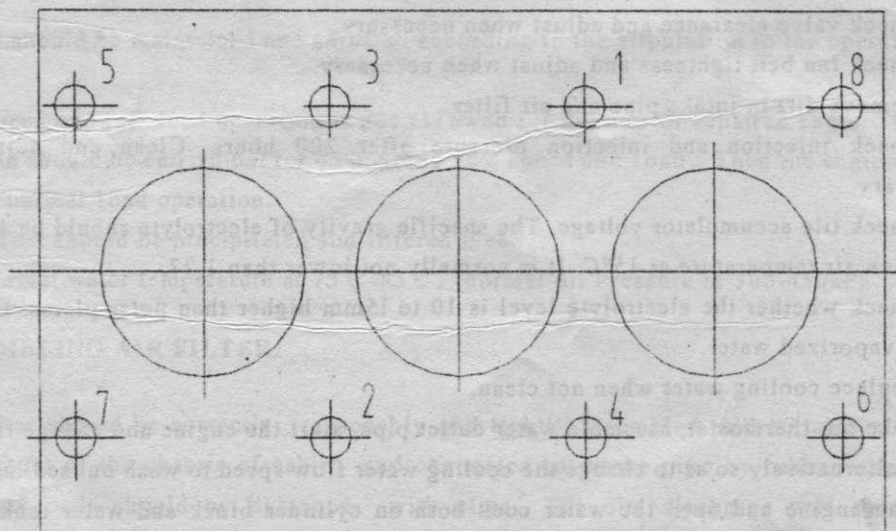

Fig.1 cylinder head bolts tighten sequence

Besides the according to

4. ENGINE

To store after engine Carry o Disasse crankshaft t and piston Remov rubber and Cover Engine Chemi The above is overdue

Besides the above mentioned procedures, you may carry out more detail maintenance according to your, own condition.

4. ENGINE PRESERVATION AND STORAGE.

To store the engine for long time, immediately drain out oil, cooling water and fuel after engine stops. Clean oil sump and oil filter cartridge.

Carry out maintenance procedure accordingly.

Disassemble intake and exhaust pipes. Fill 50g dewatered clean oil into air port and turn crankshaft to make the oil smoothly cover the valves, cylinder head, cylinder liner, piston and piston rings etc.

Remove all dirt from engine surface; brush the unpainted parts with butter except rubber and plastic parts.

Cover the mouths of air filter and silencer, wrapped in plastic paper.

Engine should be stored in place of dry, clean and good ventilation.

Chemical medicine is strictly prohibited nearby.

The above preservation method could store the engine for 3 months, if the preservation is overdue, the engine should be preserved as above again.

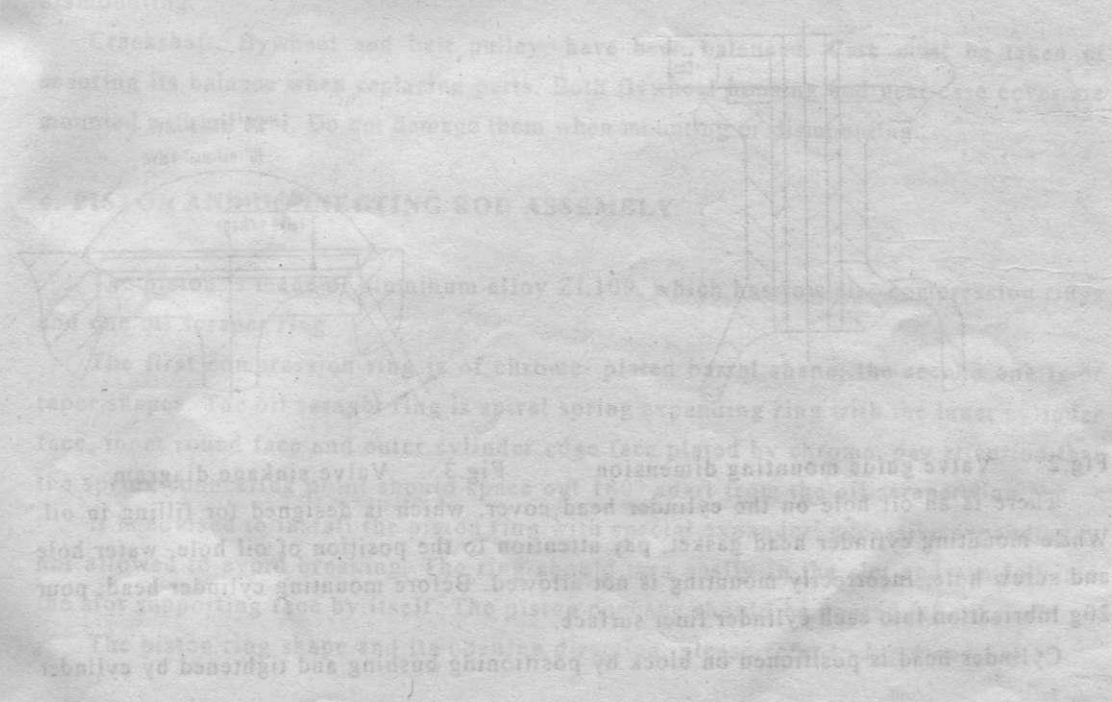

CHAPTER IV THE STRUCTURE OF ENGINE

1. CYLINDER BLOCK ASSEMBLY.

The cylinder block is planer-type with the full supporting bearing and dry cylinder liner, which the shoulder is 0.02 - 0.10mm higher than the cylinder block upper surface. The height difference of adjacent liner is not more than 0.03mm.

Dismounting cylinder liners must use the special tools and should keep the cylinder bore inner surface and the cylinder liner outer surface dry and clean, coating grease is prohibited.

The water cavity of cylinder block is tested by 400kpa water pressure for 2 minutes. The oil channel should be tested by 600kpa oil pressure for 1 minute, and leakage is not allowed.

Cylinder block have valve tappet cavity opener, a connecting pipe on the cover plate connects with breather. The oil filter and water drain cock is assembled on the cylinder block by the side of injection pump.

2. CYLINDER HEAD ASSEMBLY

Cylinder head is a unitary one, and is made of HT200 cast iron plus to cuprum chromium or HT250 cast iron.

Cylinder head water cavity is tested by 400kpa water pressure for 3 minutes. No leakage is allowed. Valve guide is pressed into cylinder head leaving a protruding of 10mm, shown as Fig.2. The cone angles of intake and exhaust valve are respectively 90° and 120° . The width of contacting surface is 1.2--1.7mm. The sinkage of intake and exhaust valve is 0.7-0.9 mm shown as Fig.2.3.

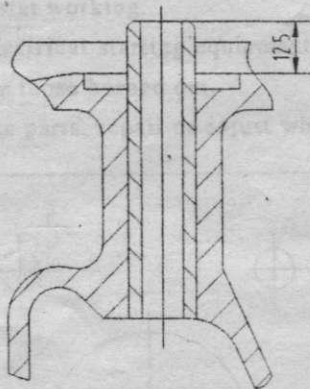

Fig.2 Valve guide mounting dimension

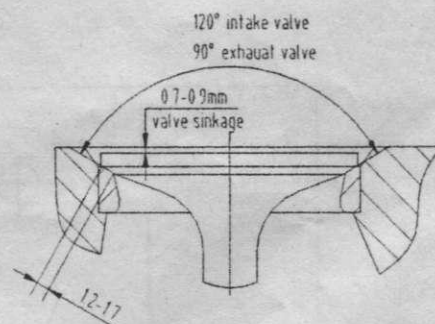

Fig.3 Valve sinkage diagram

There is an oil hole on the cylinder head cover, which is designed for filling in oil. While mounting cylinder head gasket, pay attention to the position of oil hole, water hole and screw hole. Incorrectly mounting is not allowed. Before mounting cylinder head, pour 20g lubrication into each cylinder liner surface.

Cylinder head is positioned on block by positioning bushing and tightened by cylinder

head bolts. Tightening torque is 135~150N.m which should be effected twice.

CRANKSHAFT AND FLYWHEEL ASSEMBLY

Crankshaft is made of QT900-3 nodular cast iron. Main bearing is made of steel back 20% alloy with high tin and aluminum which can't adhere oil while mounting to avoid affecting its radiating efficiency and damaging bearings. The thrust plate is of the same material as main bearing. They are mounting on two sides of the last main bearing and positioned by the convex tail of the lower thrust plate. When mounting, the oil channel of thrust plate should face to crankshaft thrust surface. Reverse mounting is not allowed.

Main bearing cover is machined in couple with cylinder block. Cylinder block No. and sequence No. are engraved on main bearing cover. The forth-main bearing cover is positioned by positioning bushing. When mounting, the top arrow on main bearing should back- face to the side of camshaft and compile the number from front end. Reverse mounting is not allowed. Tightening torque of main bearing bolts is 115~130N.m. when tightening, firstly tighten the central one, then the two sides alternatively. After tightened, the crankshaft should run freely.

Flywheel is positioned by pin and tightened by bolts on the crankshaft rear end. Bolts are tightened at a torque of 50 - 60 N. m alternatively on diagonal line. The belt pulley is positioned by starting paw, tightened at a torque of 160-170 N.m on the crankshaft front end. Pounding or beating is strictly prohibited when mounting or dismounting.

Crankshaft, flywheel and belt pulley, have been balanced. Care must be taken of ensuring its balance when replacing parts. Both flywheel housing and gear case cover are mounted with oil seal. Do not damage them when mounting or dismounting.

4. PISTON AND CONNECTING ROD ASSEMBLY

The piston is made of aluminum alloy ZL109, which has tow air--compression rings and one oil scraper ring.

The first compression ring is of chrome- plated barrel shape; the second one is of taper shapes. The oil scraper ring is spiral spring expanding ring with the inner cylinder face, inner round face and outer cylinder edge face plated by chrome, pay attention that the spring connecting point should space out 180° apart from the oil scraper ring gap.

It is advised to install the piston ring with special expander; excessive expanding is not allowed to avoid breaking. The ring should turn easily in the slot and can fall into the slot supporting face by itself. The piston concave should be poured lub.oil.

The piston ring shape and its opening direction, please refer to Fig.4 and Fig.5

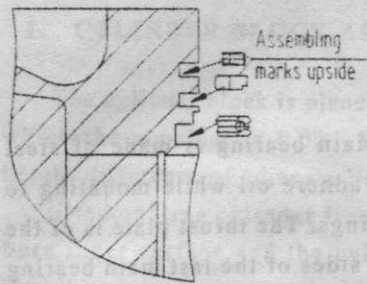

Fig.4 Piston ring shape

The connecting rod is made of 35CrMoA. There is coupling mark on the body and cap. You must install according to the mark; wrong installing should be avoided. The tightening torque of the connecting rod bolts is 80 - 90N.m.

The connecting rod bearing is made of steel back alloy with aluminum, tin, silicon and cuprum.

While mounting the piston pin, the piston should be heated to 100°C, while mounting the connecting rod, the piston top face to the installer, the tub concave is on the upper side, and the bearing positioning slot in the connecting rod big end hole should also be on the lower side.

The weight of connecting rod big end & small end has a strict distribution portion; the weight difference of piston and connecting rod assembly of each engine should be limited to below 20g.

5. DRIVING MECHANISM

The gear driving system of the engine, please refer to Fig.6.

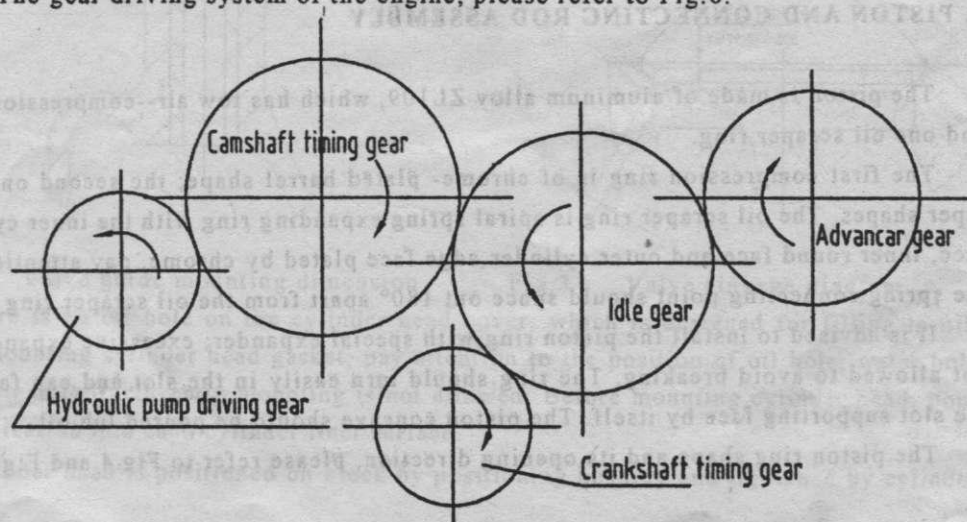

Fig.6 Driving mechanism

When in
ensure good
After in
without clic

6. VALVE

Valve
The m
choicely. T
thrust plate
Valve
tappets cen
during ope
other end i
arm and sh

Valve
check its
allowed.
to damag
requirem

A ch
and burn

Valv
Valv
accordin

0.20-0.3
procedur

Mak
pulley is
clearanc
gauge. T
every val

7. FUEL

The
fuel filt
from fue
pump by
pipe.

When installing the gears, pay attention to the timing mark on the gear faces to ensure good phasing and fuel delivery.

After installing the idle gear, check axial clearance. Each gear should turn easily without clicking.

6. VALVE SYSTEM

Valve mechanism:

The mechanism is top - mounted valve type. The camshaft is made of No. 45 steel choicely. The surfaces of camshaft and gear are high frequency quenched. There is a thrust plate in front of first shaft journal. Axial clearance of camshaft is 0.09-0.245 mm.

Valve tappet is made of chilled casting iron. There is a position deviation between tappets center and cam center, so that the tappet could continuously turn for smooth wearing during operation to prevent seizing. Push rod is made of steel; one end is bail structure, the other end is of bowl structure. Rocker arm shaft is fully supported for high rigidity. Rocker arm and shaft are lubricated by pressed oil from cylinder head.

Valve and valve seat are made of alloy steel and alloy cast iron and lapped to fit. To check its fitting, pour kerosene into air port and wait for 2 minutes, no leakage is allowed. Air leakage of the valve may affect engine technical performance or even burn to damage valve and seat. So leakage check should be carried out according to technical requirement when in operation. Lap it when necessary.

A chamfer is designed on valve guide to prevent oil flowing back into cylinder liner and burning.

Valve clearance adjustment:

Valve clearance shall affect engine performance. It should be checked and adjusted according to technical maintaining stipulation. The intake valve cooling clearance is of 0.20-0.30mm, the exhaust valve cooling clearance is of 0.25-0.35mm. The adjusting procedure as following:

Make the first cylinder piston stop at T.D.C. position when the "0" mark on crankshaft pulley is aligned with the arrow mark on gear case cover, then check and adjust valve clearance of the first valve (count from the engine front end) by inserting a valve clearance gauge. Turn the crankshaft 180° subject to the cylinder working order 1 - 3 - 2 to adjust every valve clearance.

7. FUEL SUPPLY SYSTEM

The fuel supply system consists of delivery pump, injection pump, speed adjustor, fuel filter, injector, delivery pipe and injection pipe etc. Fuel is delivered to fuel filter from fuel tank by delivery pump where the fuel is filtered and transferred to injection pump by a high pressure and atomized, then injected into chamber through injection pipe.

1) The fuel delivery pump is of piston type and assembled on the side of injection pump. When in normal operation it is driven by the eccentric camshaft gear of injection pump. Air inside the system can be discharged by manual pump when necessary after the engine stopped.

2) Fuel filter cartridge is made of paper, which should be mounted correctly to ensure completely sealing. To keep fuel clean, replace and clean the cartridge as instruction, otherwise some elements might be choked or worn out to cause trouble or shorten service life.

3) The injection pump is BQ pump or IW pump, and the plunger diameter of injection pump is 7mm for swirl type engine and 7.5mm for direct type engine. Lubrication oil is filled into injection pump from right upper side until oil drop out from side pipe for complete lubrication. Oil refilling should be carried out periodically.

Injection pump disassembling:

Try not to turn the crankshaft after the pump is disassembled so that to ensure the fuel supplies timing. Otherwise the marks on idle gear and pump gear should be aligned again by turning tile crankshaft.

Adjust fuel supply timing:

To adjust the angle, firstly discharge air in fuel system, crank the crankshaft to let injection pump fill fuel. Dismounting injection pipe on first cylinder. Blow off the air in the hole of delivery valve seat connector, then crank the crankshaft slowly and inspect the fuel level in delivery valve seat connector, stop cranking immediately when fuel level waves. Check the mark on crankshaft belt pulley to see whether the advance angle is in comply with the above mentioned specification. Larger or smaller advance angle can be adjusted by loosening three bolts on pump connecting plate. If the angle is larger, turn the gear seat counter clockwise a proper angle. If tile angle is smaller, turn it clockwise for a proper angle, then tighten three bolts and check the angle again.

Adjust injection pump:

Injection pump was already adjusted, checked and lead sealed before ex--works. If readjustment is necessary, it should be made on special testing machine at repairing workshop.

Injection pipe: inner diameter x outside diameter x length = $\phi 1.6 \times \phi 6 \times 340\text{mm}$

Injector:

Open pressure of injector and injector nozzle of every model engine refers to operation manual page 4 and page 2.

Higher or lower injection pressure shall affect normal injection. When the part is damaged, the engine shall exhaust black smoke, lower power and speed, raise exhaust temperature or knock the cylinder. To check the trouble injector, loosen injection pipes one by one, stop injection, and inspect the color of exhaust smoke. Only the trouble injector stop injection can make the engine no smoke, crank the crankshaft slowly to check injection sound of each injector, the trouble injector shall be no sound injection.

Injector adjustment:

Set injector on testing machine; slowly increase pressure to pressure required in main technical specification table. Check to ensure no fuel drops or leakage, otherwise clean or lap the nozzle and try again.

Then check atomization at a speed of one injection per second. Atomized injection should be smooth and fog shape without split, drops, uneven or partial injection but with obvious and melodious sound when fuel supply is cut off. Generally speaking, an abnormal injection is caused by unsmooth movement of plunger and barrel. While fuel drops in injection hole is caused by damaged sealing surface, and uneven injection is caused by heat deflection due to carbon deposit on head.

Injector dismantling:

When dismantling injector, firstly clean outside surface. Clamp it on bench vice with nozzle toward upside. Note that the vice mouth should be covered with copper plates. Screw out the tightening nut, pull out plunger and barrel and put in clean diesel. Turn the injector upside down and clamp again. Screw out pressure adjusting screw and nut, then take out pressure adjusting spring and push rod. Clean the plunger and barrel when they are seized or effect poor atomization. Sink it in diesel for a while when seized, clamp it with cloth covered clipper and lightly turn out the plunger. To clean plunger and barrel, scrap with wooden sheet dip in gasoline or diesel, metal sheet is strictly prohibited. If plunger can't move smoothly in barrel, lap it with clean diesel, then clean to remove all dirty and metal chips.

Speed adjustor:

Speed adjustor is well adjusted and lead sealed when ex-works. Don't adjust it unless necessary.

Adjust speed controller only on pump testing bench to prevent damaging.

8. LUBRICATION SYSTEM

Lubrication system which effect pressure and splash lubrication consists of oil pump, oil filter and oil channel.

Oil pump is of rotor type and is driven by camshaft gear. The gear shaft and camshaft gear are lubricated by splashed oil. Oil filter is of paper cartridge type, which should have a good sealing. While installing the cartridge, care must be taken to prevent leakage or short-way. The system working pressure is 300-450kpa.

To ensure a longer service life, maintain the lubrication system completely and in time.

9. COOLING SYSTEM

Cooling system is of closed, forced water-cooled, which consists of water pump, thermostat, fan, connecting pipe and radiator etc.

The cooling water in radiator is pumped into cylinder block water cavity, then to

cylinder head. Some water directly flows up to cylinder head and accumulated near thermostat. Some water holes in cylinder block and head are very small, so care must be taken not to block them especially those holes between cylinder bores and the triangle area where injection nozzle located to prevent trouble caused by overheating. Water pump is centrifugal type. If there is trouble in water seal, water may leak out from overflowing hole, repair it in time. After long time operation, some deposit shall be left in cooling system which can be removed by the following procedure:

Pour the mixture of 700-800g NaOH and 150g kerosene into water cooling system. Run the engine for 5-10 minutes, then stop for 10 - 12 hours. Restart the engine for 10 - 15 minutes, drain out the mixture and clean cooling system with clear water.

10. ELECTRIC SYSTEM

Electric system consists of generator, starting motor, regulator, accumulator, oil pressure sensor, glow plug and connecting wire etc. Engine normal voltage is 12v.

The negative pole of accumulator and generator should be earthed; positive and negative pole can't be short circuit to prevent damage.

Tr
1. I
1) M
2) A
3) F
4) P
5) L
2. Ele
1) Imp
2) Lov
3. Hig
speed.
4. Amb
5. Low
1) Cylir
2) Valv
3) No va
4) Valve
5) Air lea
6) Air lea
7) Valve t

CHAPTER V ENGINE TROUBLES AND REMEDY

A: ENGINE CAN NOT BE STARTED

Trouble Cause	Remedy
1. Fuel System 1) No fuel in fuel tank or fuel cock not opens. 2) Air in fuel system 3) Fuel pipes or fuel filter blocked. 4) Poor atomization 5) Lever not return to max. fuel supply position.	1) Fill in fuel or open fuel cock. 2) Discharge air by manual delivery pump. Check each connection for leakage. 3) Clean pipes and filter cartridge or replace cartridge. 4) Clean nozzle; Adjust injection pressure. 5) Pull the speed adjustor lever with force when starting to force the lever to max. fuel supply position.
2. Electrical System 1) Improper circuit contact 2) Lower voltage of accumulator	1) Tighten the circuit connecting screw. 2) Charge the accumulator.
3. High oil viscosity to lower the engine starting speed.	3. Cranking the crankshaft for several turns with cranking handle, or fill in preheated oil.
4. Ambient temperature too low.	4. Fill in hot water to pre- heat starting
5. Lower Compression Pressure in cylinder. 1) Cylinder liner, piston and piston rings worn out. 2) Valve and valve seat fitting not good. 3) No valve clearance. 4) Valve stem blocked in valve guide. 5) Air leakage from cylinder head gasket. 6) Air leakage from injector seat. 7) Valve timing incorrect.	1) Replace new parts. 2) Lap valves. 3) Adjust clearance according to technical requirement. 4) Clean it in kerosene or diesel. 5) Check cylinder head nuts torque. check whether the gasket is broken . 6) Check nuts and packing for tightness and damage 7) Check and adjust.

6. Fuel supply advance angle not correct.	6. Check and adjust it.
---	-------------------------

B: ENGINE POWER DECLINE.

Trouble Cause,	Remedy
1. Air filter or intake pipe blocked	1. Clean it.
2. Exhaust pipe blocked	2. Clean it.
3. Insufficient fuel supply. 1) Delivery pipe & fuel filter blocked. 2) Nozzle tip worn out.	1) Clean it. 2) Replace nozzle tip or injector.
4. Water in fuel	4. Replace fuel.
5. Incorrect fuel supply advance angle.	5. Adjust
6. Too much carbon deposit in chamber.	6. Disassemble cylinder head and remove carbon deposit.

C: ENGINE STOP SUDDENLY

Trouble Cause	Remedy
1. No fuel supply. 1) No fuel in tank. 2) Air in fuel system 3) Fuel filter blocked 4) Water in fuel.	1) Fill in fuel. 2) Discharge air. 3) Clean it. 4) Replace fuel.
2. Piston blocked	2. Replace it.
3. Air filter blocked.	3. Replace filter cartridge.

D: ENGINE RUNNING WITH KNOCKING SOUND.

Trouble Cause	Remedy
1. Fuel supply too early or too late.	1. Readjust fuel supply advance angle.
2. Valve clearance to big	2. Readjust valve clearance.
3. Too big clearance between piston and cylinder liner.	3. Check and replace piston or cylinder liner when necessary.
4. Too big clearance between piston pin and connecting rod bushing, having beating sound.	4. Check and replace connecting rod bushing when necessary.
5. Too big clearance of main bearing or connecting rod bearing, having ramming sound.	5. Check and replace connecting rod bearing or main bearing when necessary
6. Valve knock with piston top.	6. Adjust timing phase.

E: OIL

Trouble
1. Insuffi
2. Oil pi
3. Oil vi
4. Cylin
case cov
5. Suctio
6. Oil pu
7. Too l
connecti
8. Impr
oil filter
9. Oil pi
10. Wro

F: E

1. Cooli
1) No w
2) Too r
3) Fan a
4) Spac
5) Wate
2. Fuel i
3. Oil in
temperat
4. Valve
5. Thern
6. Engin

E: OIL PRESSURE TOO LOW.

Trouble Cause	Remedy
1. Insufficient oil in sump.	1. Fill in oil.
2. Oil pipes or oil filter cartridge blocked.	2. Clean and replace when necessary.
3. Oil viscosity too low.	3. Replace oil according to technical requirement.
4. Cylinder head gasket, water pump packing or gear case cover packing damaged to induce water into oil.	4. Replace damaged gasket, packing and oil
5. Suction fuel pipe connector leakage	5. Check and repair it
6. Oil pump rotors seriously worn out.	6. Replace rotors and adjust clearance.
7. Too large clearance between main bearing and connecting rod bearing.	7. Check and replace when necessary.
8. Improper adjustment of pressure adjusting valve on oil filter.	8. Readjust it
9. Oil pressure gauge damaged	9. Replace it
10. Wrong assembling of oil filter seat packing	10. Reassemble it

F: ENGINE OVER HEAT

Trouble Cause	Remedy
1. Cooling system out of order 1) No water in radiator 2) Too much deposit in water passage 3) Fan and water pump belt too loose. 4) Space between radiator and fan is not suitable. 5) Water inlet and outlet pipe deformed or blocked	1) Fill in water 2) Add alkaline solution (750g alkaline in 10 L water), operating 4 - 8 hours and discharged, then use clean water to clean the passage. 3) Adjust the tension of belts or change belt when necessary. 4) Adjust it. 5) Replace it.
2. Fuel injection delayed or nozzle leaks fuel.	2. Adjust the fuel delivery advance angle or repair nozzle.
3. Oil insufficient causes oil pressure too low and temperature too high.	3. Add oil.
4. Valve phasing is incorrect.	4. Adjust it.
5. Thermostat out of order.	5. Replace it.
6. Engine running overload for a long period.	6. Reduce load.

G: ENGINE EXHAUST ABNORMAL SMOKE.

Trouble Cause	Remedy
<p>1. Exhaust blue smoke (oil in cylinder)</p> <p>1) Piston rings, cylinder liner worn out or piston rings jammed.</p> <p>2) Intake or exhaust valve guide hole worn out.</p> <p>3) Too much oil in oil sump.</p>	<p>1) Repair or replace it.</p> <p>2) Replace it.</p> <p>3) Drain out some oil.</p>
<p>2. Exhaust white smoke (Engine in cold condition with bad fuel atomization in low load condition.)</p> <p>1) Fuel injection pump delivery too much fuel.</p> <p>2) With bad fuel atomization, fuel pressure is too low</p> <p>3) Fuel delivery too late</p> <p>4) Cylinder compressing pressure is low.</p> <p>5) Fuel with water</p>	<p>1) Adjust fuel delivery.</p> <p>2) Inspect injection pressure or replace fuel injector when necessary.</p> <p>3) Adjust fuel advance angle</p> <p>4) Refer to a-5</p> <p>5) Replace fuel.</p>
<p>3. Exhaust black smoke (bad combustion)</p> <p>1) Engine overloaded</p> <p>2) Nozzle with bad atomization or leak fuel</p> <p>3) Fuel delivery too late</p> <p>4) Air filter blocked.</p> <p>5) Too much fuel delivery</p>	<p>1) Reduce the load.</p> <p>2) Adjust or replace the nozzle.</p> <p>3) Adjust the fuel delivery advance angle.</p> <p>4) Clean air filters and air intake pipe or replace filter cartridge.</p> <p>5) Adjust the fuel delivery.</p>

H: FUEL

1. No fuel d
- 1) Delivery
- 2) Delivery
- 3) Adjusting
- 4) Adjusting
- 5) Delivery
2. Fuel injec
- the engine.
- 1) Adjusting
- 2) Adjusting
- 3) Governo
- 4) Pulling ba
- 5) Flyweight
- 6) Pulling ba
3. Speed gov
- 1) Governin
- 2) Calibrator
4. Unsteady
- 1) Air or wat
- 2) Delivery p
- 3) Plunger sp
5. Unsteady c
- 1) Governor
- 2) Camshaft
- 3) Governing
- 4) Fly weight
- 5) Too much
6. Insuffici
- 1) Pump elem
- 2) Calibrator
- 3) High speed
7. Uneven fue
- 1) Adjusting a
- 2) Plunger spr
- 3) Delivery va

H: FUEL INJECTION PUMP OUT OF ORDER

Trouble Cause	Remedy
1. No fuel delivery 1) Delivery valve burn out or with dirt 2) Delivery valve spring or plunger spring deformed or broken. 3) Adjusting arm broken down. 4) Adjusting arm and fork jammed 5) Delivery pump stem jammed	1) Replace or clean delivery valve. 2) Replace it. 3) Tighten the adjusting arm. 4) Inspect and repair it. 5) Inspect and repair it.
2. Fuel injection pump supply fuel all the time ,causes running away of the engine. 1) Adjusting arm and fork jammed 2) Adjusting arm come down. 3) Governor sleeve burn out because of bad lubrication. 4) Pulling bar stroke not enough. 5) Flyweight loosen 6) Pulling bar spring come down	1) Inspect and repair it. 2) Replace or tighten it. 3) Inspect and repair it. 4) Adjust its stroke. 5) Tighten it. 6) Adjust it.
3. Speed governing rate too high 1) Governing spring deformed or worn out. 2) Calibrator works too early.	1) Replace the spring 2) Adjust it.
4. Unsteady fuel delivery. 1) Air or water in fuel. 2) Delivery pump damaged. 3) Plunger spring broken.	1) Discharge air or water. 2) Repair or replace it. 3) Replace plunger spring.
5. Unsteady operating of the engine 1) Governor internal friction too high. 2) Camshaft axial clearance too big 3) Governing spring deformed or rigidity too small 4) Fly weight loose 5) Too much lub.oil	1) Inspect and solve it. 2) Adjust the clearance. 3) Replace it. 4) Tighten it. 5) Add lub.oil as requirement
6. Insufficient fuel supply, 1) Pump element or delivery valve worn out. 2) Calibrator out of order. 3) High speed limit abnormal	1) Replace it. 2) Adjust it. 3) Adjust it.
7. Uneven fuel delivery of each cylinder 1) Adjusting arm loosen. 2) Plunger spring broken, 3) Delivery valve or nozzle with dirt.	1) Tighten it. 2) Replace it, 3) Clean it.

8. Engine unsteady in low speed. 1) Idle speed screw not correct. 2) Uneven fuel supply in low speed.	1) Adjust it. 2) Adjust it.
---	--------------------------------

I. STARTER IS OUT OF ORDER

Trouble cause	Remedy
1. The starter can't work. 1) Connecting wire is broken or bad connection. 2) The fuse is broken 3) The accumulator is no power or insufficient power. 4) The electric brush can't connect with the commutator. 5) The starter is short circuit. 6) The bearing sleeve is worn out. 7) The clutch is sliding.	1) Weld it or replace new wire. 2) Replace it. 3) Recharge or replace it. 4) Adjust brush and spring pressure. 5) Check and resolve the short. 6) Replace it. 7) Adjust it.
2. The starter can run in empty load, but not start the engine. 1) The shaft bushing is worn out, the armature rubs with the magnetic pole. 2) The electric brush badly connects with the commutator. 3) The surface of commutator is burnt out or with oil dirt. 4) The armature coil seal off with the commutator. 5) The wire connection is bad. 6) The electric-magnetic switch's connection spot is burnt out and causes a bad connection. 7) The accumulator is insufficiently recharged or the voltage is not in conformity with the requirement.	1) Replace new bushing. 2) Clean brush and commutator surface. 3) Clean oil dirt and polish it. 4) Weld it. 5) Screw down the nuts, 6) Check the switch connecting spot and polish it. 7) Recharge or replace the accumulator.
3. Loosen the switch, but the starter continue to run. 1) The electric-magnetic switch connecting spot has been melted together. 2) The eccentric screw is not adjusted in proper position. 4. The starter's gear badly mesh with the flywheel gear ring	1), Check and polish the connecting spot. 2). Adjust eccentric screw (forward). 4. Adjust eccentric screw (rearward).

J. 1

Trout

1. The

1). Th

2). Th

3). Sil

4). Ele
alterna

5). The
spot is

2. The

1). Son

2). The
pressur

3). The

burnt ou

4). The

3. The c

1). The

2). The

lower, th

3). The a

4). The n

5). The n

4. There

1). The al

2). The al

3). The al

5. The chu

1). The re

J. ALTERNATOR IS OUT OF ORDER

Trouble cause	Remedy
<p>1. The alternator can not generating power.</p> <p>1). The wire is broken or wrong connection.</p> <p>2). The stator and rotor coil is broken or short circuit.</p> <p>3). Silicon rectifier damage to cause breaking or short circuit.</p> <p>4). Electric brush is bad connection, sliding ring is dirty and alternator v-belt is too loosened.</p> <p>5). The regulator's regulating voltage is lower, its connecting spot is burnt out or oxygenated, the relay coil is burnt out.</p>	<p>1). Check and repair it.</p> <p>2). Repair or replace it.</p> <p>3). Replace it.</p> <p>4). Clean and repair it.</p> <p>5). Repair and replace it.</p>
<p>2. The charged power is insufficient.</p> <p>1). Some of alternator's silicon elements is broken circuit.</p> <p>2). The alternator's electric brush is bad connection, spring pressure is lower, the sliding ring is dirty.</p> <p>3). The regulator's regulating voltage is lower; its connecting spot is burnt out.</p> <p>4). The accumulator's electrolyte is less</p>	<p>1). Repair or replace it.</p> <p>2). Clean and repair it.</p> <p>3). Repair or replace it.</p> <p>4). Fill the electrolyte or replace it.</p>
<p>3. The charged current is unstable.</p> <p>1). The stator and rotor coil will be short or broken circuit.</p> <p>2). The alternator electric brush is bad connection; spring pressure is lower, the sliding ring is dirty.</p> <p>3). The alternator v-belt is loosened.</p> <p>4). The regulator's connecting spot is dirty</p> <p>5). The regulator is out of order.</p>	<p>1). Repair or replace it.</p> <p>2). Clean, repair or replace it.</p> <p>3). Adjust or replace it.</p> <p>4). Clean it.</p> <p>5). Repair or replace it.</p>
<p>4. There are abnormal sounds in the alternator.</p> <p>1). The alternator installing is not correct, bearing is damaged.</p> <p>2). The alternator's stator coil or silicon elements are short.</p> <p>3). The alternator's moving parts knock or rub with the fixed parts</p>	<p>1). Repair or replace it.</p> <p>2). Repair or replace it.</p> <p>3). Repair it.</p>
<p>5. The charged power it excessive</p> <p>1). The regulator's regulating voltage is higher or it is out of order.</p>	<p>1). Repair or replace the regulator.</p>

6. The alternator is burnt out and damaged.	
1). The alternator's silicon elements is short circuit or its stator knocks the rotor.	1). Repair it.
2). The regulator's coil is burnt out and damaged or the connecting spot is burnt out and melted Together cause it is out of order.	2). Repair or replace it.
3). The regulator's voltage coil or resistance wire is broken.	3). Repair it.



3T30 系列柴油机说明书

**DIESEL ENGINE MODEL 3T30 SERIES
OPERATION MANUAL**

SHANDONG HUAYUAN LAIDONG ENGINE CO., LTD.

山东华源莱动内燃机有限公司

Add : 40,Wulong North Road,
Laiyang City ,Shandong , China
FAX:0086-535-7215149
E--mail : ldworks@ec . com . cn
(LL385BT-35500-1)